

## U12A-22 Utility Air Winch

### Description:

The Model U12A-22 Utility Winch follows in the footsteps of Wintech's very popular U-8 Series Portable Air Winches, but has the added benefits of higher line pull and more cable storage capacity. The Model U12A-22 is a rugged yet economical air tugger designed for in-plant maintenance, construction, mining, oilfield and marine industries. A precision engineered worm drive gearbox with oil bath ensures positive load holding for excellent position control.

### Standard Features:

- Heavy duty steel frame and steel drum
- Fully enclosed worm gearbox provides positive load holding and positioning characteristics
- Direct mounted fully reversing directional control valve with proportional handle for simultaneous speed control
- Bolt down mounting feet
- Dual mufflers are standard for quieter operation

### Optional Features:

- Hand held remote pendant with push button controls
- In-line filter/lubricator/regulator assembly
- Winch cables
- Extended drum lengths



Cable Layer	Linepull* (lbs)	Line speed* (fpm)
Core	2,240	23
Mid Drum	1,700	30
Full	1,400	36

\* Performance data is based on air supply of 125 CFM at 90 PSI

Cable Size	Cable Layer	Cumulative Cable (ft)
1/4"	Core	66
	Mid Drum	380
	Full	600
5/16"	Core	53
	Mid Drum	180
	Full	400
3/8"	Core	45
	Mid Drum	150
	Full	280

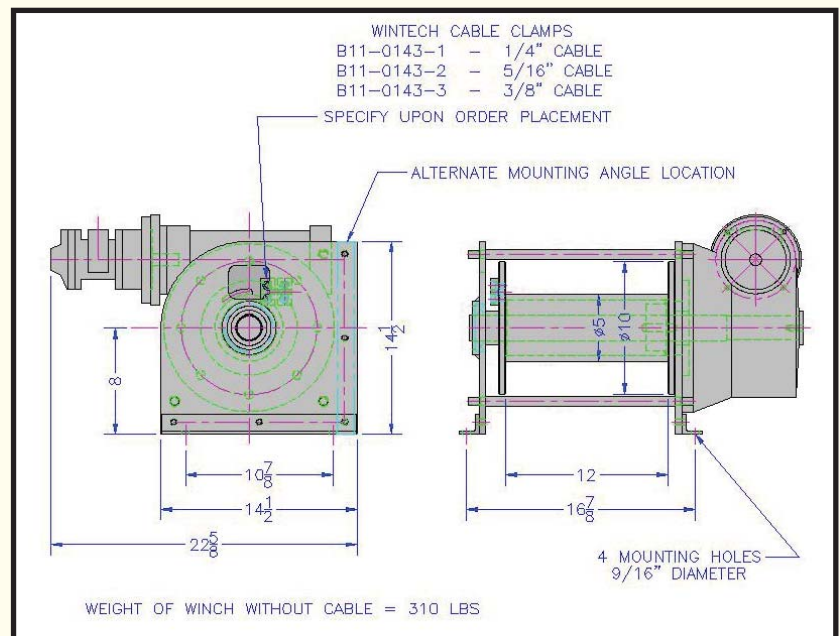

Made in the USA

